

Toolholders DIN 2080

Porte-outils DIN 2080

Vorgewuchtet
Pre-balanced
Pré-équilibré

G 6,3 15.000 min⁻¹

G 2,5 Feinwuchten gegen Aufpreis

G 2.5 Fine balancing at extra charge

G 2,5 Equilibrage fin contre un supplément

- ★ Mit Kunststoff-Kantenschutzring
- ★ With plastic protection ring
- ★ Avec bague de protection en plastique

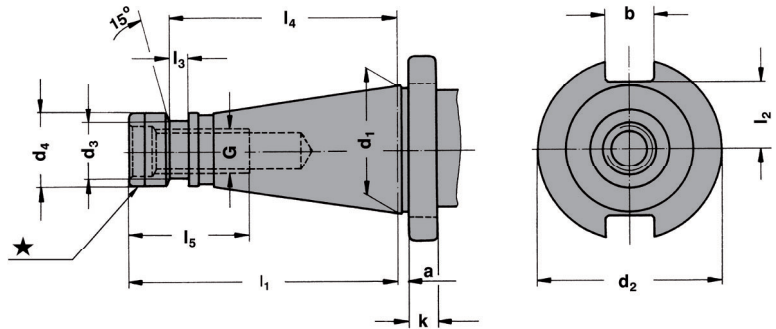

4

SK	d ₁	a	b	k	G	d ₂	d ₃	d ₄	l ₁	l ₂	l ₃	l ₄	l ₅
30	31,75	1,6	16,1	8	M12	50,0	-	17,2	68,4	16,2	-	-	24,0
40 ★	44,45	1,6	16,1	10	M16	63,0	21,1	25,0	93,4	22,5	7,0	82,0	32,0
50 ★	69,85	3,2	25,7	12	M24	97,5	32,0	39,2	126,8	35,3	13,0	115,0	47,0

Werkstoff: Legierter Einsatzstahl mit einer Zugfestigkeit im Kern von min. 800 N / mm². Einsatzgehärtet HRC 60 ± 2 (HV 700 ± 50), Härtetiefe 0,8 mm ± 0,2 mm, brüniert und präzisionsgeschliffen.

Genauigkeit: Kegelwinkel - Toleranzqualität < AT 3 nach DIN 7187 und DIN 2080.

Material: Alloyed case-hardened steel, tensile core strength of min. 800 N / mm². Case hardened HRC 60 ± 2 (HV 700 ± 50), hardening depth 0.8 mm ± 0.2 mm, black-finished and precisely grinded.

Accuracy: Quality of taper < AT 3 according to DIN 7187 and DIN 2080.

Matière: Acier de cémentation allié. Résistance à la traction dans le noyau de min 800 N / mm². Cémentation à HRC 60 ± 2 (HV 700 ± 50), profondeur de cémentation 0,8 mm ± 0,2 mm, bruni et rectifié précisément.

Précision: Qualité du cône < AT 3 selon DIN 7187 et DIN 2080.

Toolholders DIN 2080

Porte-outils DIN 2080

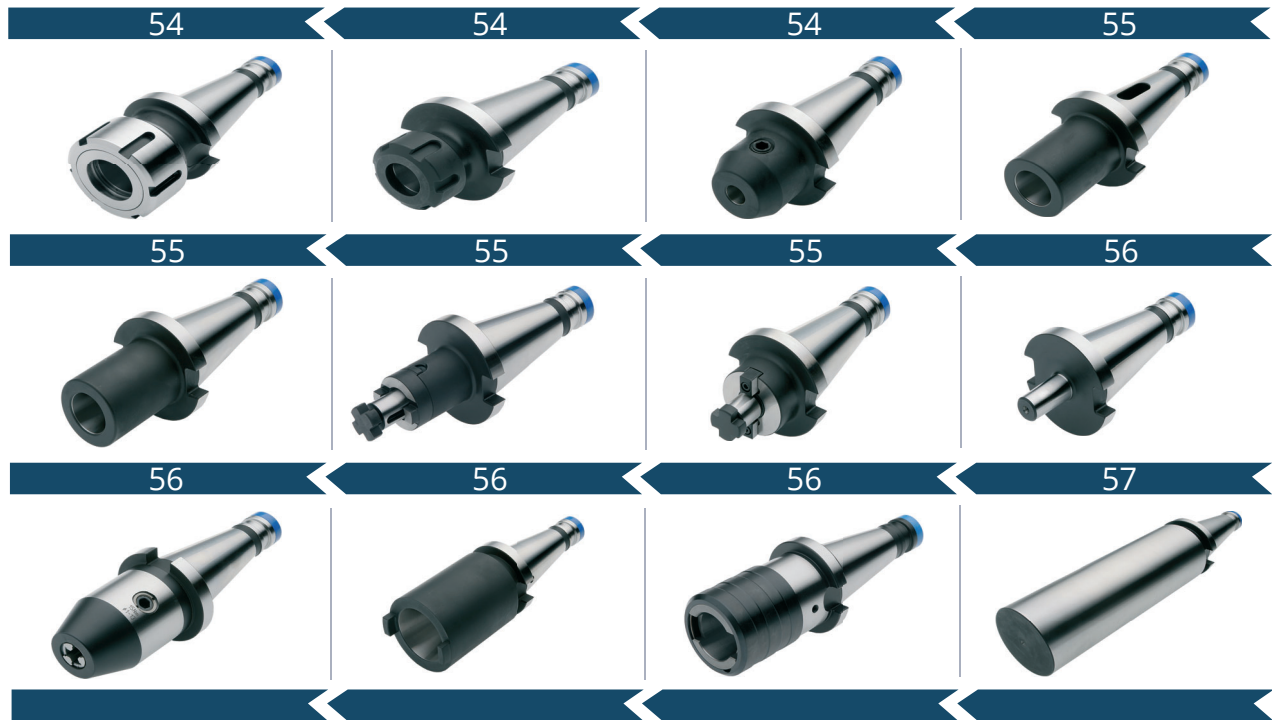

Toolholders DIN 2080

Porte-outils DIN 2080



Spannfutter DIN 6391
für Spannzangen DIN 6388
(ISO 10897) System OZ
Collet chucks DIN 6391 for collets
DIN 6388 (ISO 10897) OZ-system
Mandrins à pinces DIN 6391
pour pinces DIN 6388
(ISO 10897) système OZ

DIN 2080

$\nearrow \leq 0,003$

G6,3
15.000 min⁻¹

Bestell-Nr. Order no. / Réf.	Abmessung Size / Dimension	Euro
301.01.16	SK 30 - 2 / 16 - 50 OZ 16	62,00
401.01.16	SK 40 - 2 / 16 - 55 OZ 16	62,00
401.01.25	SK 40 - 2 / 25 - 66 OZ 25	63,00
401.01.32	SK 40 - 3 / 32 - 95 OZ 32	67,00
501.01.25	SK 50 - 2 / 25 - 71 OZ 25	88,00
501.01.32	SK 50 - 3 / 32 - 73 OZ 32	93,00



109



134



136



Spannfutter für Spannzangen
DIN 6499 (ISO 15488) System ER
Collet chucks for collets DIN 6499
(ISO 15488) ER-system
Mandrins à pinces pour pinces
DIN 6499 (ISO 15488) système ER

DIN 2080

$\nearrow \leq 0,003$

G6,3
15.000 min⁻¹

Bestell-Nr. Order no. / Réf.	Abmessung Size / Dimension	Euro
301.02.16	SK 30 - 2 / 16 - 50 ER 25	51,00
301.02.20	SK 30 - 2 / 20 - 50 ER 32	53,00
401.02.16	SK 40 - 2 / 16 - 50 ER 25	51,00
401.02.20	SK 40 - 2 / 20 - 50 ER 32	53,00
401.02.26	SK 40 - 3 / 26 - 80 ER 40	56,00
501.02.20	SK 50 - 2 / 20 - 63 ER 32	81,00
501.02.26	SK 50 - 3 / 26 - 63 ER 40	81,00



110



134



136



Fräseraufnahmen DIN 6359
für Zylinderschäfte DIN 1835-B
End mill holders DIN 6359
for end mills DIN 1835-B
Porte-fraises DIN 6359 pour queues
cylindriques DIN 1835-B

DIN 2080

$\nearrow \leq 0,003$

G6,3
15.000 min⁻¹

Bestell-Nr. Order no. / Référence	Abmessung Size / Dimension	Euro
301.04.06	SK 30 - 06 - 40	41,00
301.04.08	SK 30 - 08 - 40	38,00
301.04.10	SK 30 - 10 - 40	38,00
301.04.12	SK 30 - 12 - 40	38,00
301.04.14	SK 30 - 14 - 40	38,00
301.04.16	SK 30 - 16 - 50	38,00
301.04.18	SK 30 - 18 - 50	38,00
301.04.20	SK 30 - 20 - 63	38,00
401.04.06	SK 40 - 06 - 50	41,00
401.04.08	SK 40 - 08 - 50	38,00
401.04.10	SK 40 - 10 - 50	38,00
401.04.12	SK 40 - 12 - 50	38,00
401.04.14	SK 40 - 14 - 50	38,00
401.04.16	SK 40 - 16 - 63	38,00
401.04.18	SK 40 - 18 - 63	38,00
401.04.20	SK 40 - 20 - 63	38,00
401.04.25	SK 40 - 25 - 80	44,00
401.04.32	SK 40 - 32 - 80	49,00
401.04.40	SK 40 - 40 - 90	59,00
501.04.06	SK 50 - 06 - 63	58,00
501.04.08	SK 50 - 08 - 63	56,00
501.04.10	SK 50 - 10 - 63	56,00
501.04.12	SK 50 - 12 - 63	56,00
501.04.14	SK 50 - 14 - 63	56,00
501.04.16	SK 50 - 16 - 63	56,00
501.04.18	SK 50 - 18 - 63	56,00
501.04.20	SK 50 - 20 - 63	56,00
501.04.25	SK 50 - 25 - 80	62,00
501.04.32	SK 50 - 32 - 80	67,00
501.04.40	SK 50 - 40 - 90	73,00



154

Toolholders DIN 2080

Porte-outils DIN 2080



Zwischenhülse für MK mit Austreibblappen DIN 6383
Adaptor sleeves for MT with tang DIN 6383
 Douilles de réduction pour CM à tenon DIN 6383

DIN 2080 $\nearrow \leq 0,005$ G6,3 15.000 min⁻¹

Bestell-Nr. Order no. / Référence	Abmessung Size / Dimension	Euro
301.07.01	SK 30 - 1 - 50	38,00
301.07.02	SK 30 - 2 - 50	38,00
301.07.03	SK 30 - 3 - 75	38,00
401.07.01	SK 40 - 1 - 50	38,00
401.07.02	SK 40 - 2 - 50	38,00
401.07.03	SK 40 - 3 - 65	38,00
401.07.04	SK 40 - 4 - 95	42,00
501.07.01	SK 50 - 1 - 45	54,00
501.07.02	SK 50 - 2 - 60	54,00
501.07.03	SK 50 - 3 - 65	54,00
501.07.04	SK 50 - 4 - 70	54,00
501.07.05	SK 50 - 5 - 105	59,00



Kombi-Aufsteckfräserdorne DIN 6358
Combi shell mill holders DIN 6358
 Porte-fraises à double usage DIN 6358

DIN 2080 $\nearrow \leq 0,005$ G6,3 15.000 min⁻¹

Bestell-Nr. Order no. / Référence	Abmessung Size / Dimension	Euro
301.10.16	SK 30 - 16 - 35	49,00
301.10.22	SK 30 - 22 - 35	50,00
301.10.27	SK 30 - 27 - 35	50,00
301.10.32	SK 30 - 32 - 50	54,00
401.10.16	SK 40 - 16 - 52	49,00
401.10.22	SK 40 - 22 - 52	50,00
401.10.27	SK 40 - 27 - 52	50,00
401.10.32	SK 40 - 32 - 52	54,00
401.10.40	SK 40 - 40 - 52	61,00
501.10.16	SK 50 - 16 - 55	66,00
501.10.22	SK 50 - 22 - 55	66,00
501.10.27	SK 50 - 27 - 55	67,00
501.10.32	SK 50 - 32 - 55	70,00
501.10.40	SK 50 - 40 - 55	76,00



Zwischenhülse für MK mit Anzugsgewinde DIN 6364
Adaptor sleeves for MT with drawbar thread DIN 6364
 Douilles de réduction pour CM avec filetage DIN 6364

DIN 2080 $\nearrow \leq 0,005$ G6,3 15.000 min⁻¹

Bestell-Nr. Order no. / Référence	Abmessung Size / Dimension	Euro
401.08.01	SK 40 - 1 - 50	62,00
401.08.02	SK 40 - 2 - 50	62,00
401.08.03	SK 40 - 3 - 65	62,00
401.08.04	SK 40 - 4 - 95	67,00
401.08.04A*	SK 40 - 4 - 110	74,00
501.08.01	SK 50 - 1 - 60	81,00
501.08.02	SK 50 - 2 - 60	81,00
501.08.03	SK 50 - 3 - 65	81,00
501.08.04	SK 50 - 4 - 65	88,00
501.08.04A*	SK 50 - 4 - 80	95,00
501.08.05	SK 50 - 5 - 120	91,00
501.08.05A*	SK 50 - 5 - 138	102,00

* Mit Mitnehmerausfräsung nach DIN 2201
 * With driving facilities according to DIN 2201
 * Avec fraisage d'entraînement selon DIN 2201



Quernut-Aufsteckfräserdorne DIN 6357 mit vergrößerter Anlagefläche
Shell mill holders DIN 6357 with enlarged contact face
 Porte-fraises à trou lisse DIN 6357 avec face de contact élargie

DIN 2080 $\nearrow \leq 0,005$ G6,3 15.000 min⁻¹

Bestell-Nr. Order no. / Référence	Abmessung Size / Dimension	Euro
401.11.16	SK 40 - 16 - 30	53,00
401.11.22	SK 40 - 22 - 30	53,00
401.11.27	SK 40 - 27 - 30	54,00
401.11.32	SK 40 - 32 - 30	57,00
401.11.40	SK 40 - 40 - 30	70,00
501.11.22	SK 50 - 22 - 35	70,00
501.11.27	SK 50 - 27 - 35	70,00
501.11.32	SK 50 - 32 - 40	74,00
501.11.40	SK 50 - 40 - 33	84,00
501.11.60	SK 50 - 60 - 55	129,00



Toolholders DIN 2080

Porte-outils DIN 2080



Bohrfutteraufnahmen DIN 238
Drill chuck adaptors DIN 238
 Arbres pour mandrins de perçage
 DIN 238

DIN 2080		
	$\nearrow \leq 0,005$	G6,3 15.000 min ⁻¹
Bestell-Nr.	Abmessung	Euro
<i>Order no. / Réf.</i>	<i>Size / Dimension</i>	
301.14.12	SK 30 - B12	41,00
301.14.16	SK 30 - B16	41,00
401.14.12	SK 40 - B12	41,00
401.14.16	SK 40 - B16	41,00
401.14.18	SK 40 - B18	41,00
501.14.16	SK 50 - B16	53,00
501.14.18	SK 50 - B18	53,00



Zwischenhülsen für SK-Aufnahmen
Adaptor sleeves for ISO-toolholders
 Douilles de réduction pour
 porte-outils ISO/SA

DIN 2080		
	$\nearrow \leq 0,005$	G6,3 15.000 min ⁻¹
Bestell-Nr.	Abmessung	Euro
<i>Order no. / Référence</i>	<i>Size / Dimension</i>	
401.09.30	SK 40 - SK 30 - 50	103,00
401.09.40	SK 40 - SK 40 -100	103,00
501.09.40	SK 50 - SK 40 - 50	130,00
501.09.50	SK 50 - SK 50 - 125	149,00



CNC-Bohrfutter für Rechts- und Linkslauf
CNC-Drill chucks for clockwise and counter clockwise rotation
 Mandrins de perçage CNC pour rotation droite-gauche

DIN 2080		
	$\nearrow \leq 0,030$	G6,3 15.000 min ⁻¹
Bestell-Nr.	Abmessung	Euro
<i>Order no. / Réf.</i>	<i>Size / Dimension</i>	
301.15.08	SK 30 - 0,5 / 8 - 58	328,00
301.15.13	SK 30 - 1,0 / 13 - 79	273,00
301.15.16	SK 30 - 2,5 / 16 - 84	294,00
401.15.08	SK 40 - 0,5 / 8 - 63	246,00
401.15.13	SK 40 - 1,0 / 13 - 83	218,00
401.15.16	SK 40 - 2,5 / 16 - 88	235,00
501.15.13	SK 50 - 1,0 / 13 -108	257,00
501.15.16	SK 50 - 2,5 / 16 -113	273,00



Gewindeschneid-Schnellwechselfutter mit Längenausgleich auf Druck und Zug
Quick change tapping chucks with length compensation on compression and expansion
 Mandrins de taraudage à changement rapide **avec** compensation longitudinale à la compression et traction

DIN 2080		
Bestell-Nr.	Abmessung	Euro
<i>Order no. / Référence</i>	<i>Size / Dimension</i>	
301.16.12	SK30 - M3 / M14 Gr. 1	201,00
301.16.20	SK30 - M5 / M22 Gr. 2	212,00
401.16.12	SK40 - M3 / M14 Gr. 1	201,00
401.16.20	SK40 - M5 / M22 Gr. 2	212,00
401.16.36	SK40 - M14 / M36 Gr. 3	318,00
501.16.12	SK50 - M3 / M14 Gr. 1	247,00
501.16.20	SK50 - M5 / M22 Gr. 2	259,00
501.16.36	SK50 - M14 / M36 Gr. 3	364,00



Toolholders DIN 2080

Porte-outils DIN 2080



Bohrstangenrohlinge

Boring bar blanks

Barres d'alésage

DIN 2080

Bestell-Nr. <i>Order no. / Référence</i>	Abmessung <i>Size / Dimension</i>	Euro
401.17.63	SK 40 - 63 - 250	116,00
501.17.97	SK 50 - 97 - 315	188,00

4

Gewuchtete Ausführung

Balanced type

Type équilibré



Bestell-Nr. <i>Order no. / Réf.</i>	Abmessung <i>Size / Dimension</i>	Euro
Wuchten auf G 2,5 von vorgewuchteten Kemmler-Werkzeugen		
<i>Balancing at G 2.5 of pre-balanced Kemmler-tools</i>		
<i>Équilibrage sur G 2,5 d'outils Kemmler pré-équilibrés</i>		
W25	Ohne Wuchtprotokoll <i>Without balancing report</i> Sans protocole d'équilibrage	15,00
W25.2	Mit Wuchtprotokoll <i>With balancing report</i> Avec protocole d'équilibrage	19,00
Wuchten von nicht vorgewuchteten Werkzeugen		
<i>Balancing of unbalanced tools</i>		
<i>Équilibrage d'outils non-équilibrés</i>		
W25.1	Ohne Wuchtprotokoll <i>Without balancing report</i> Sans protocole d'équilibrage	28,00